

TOWN OF HILLSBOROUGH
SAN MATEO COUNTY

Planning Division
650/375-7422
Fax 650/375-7415



1600 Floribunda Avenue
Hillsborough
California 94010

**Design Review of Fences, Walls, Entry Gates,
Columns and/or Light Posts along the street**

August 2018

Design Approval Required:

Design Review Approval is required before submitting an application for a Building Permit (which is also required) for the following:

- All fences, walls, columns and gates (regardless of height) that are along or within the street setback(s) of a property (typically the front 25 or 30 feet of the lot along the street); and,
- All fences and walls over six feet in height (regardless of location).

The Administrative Design Review process typically take 2-3 weeks to complete, unless revisions to the project proposal are required to meet minimum requirements of the Hillsborough Municipal Code.

Public Notification:

Projects reviewed administratively require public notification to all adjacent property owners (as provided by the Building and Planning Divisions), which are those properties contiguous to the subject property (including properties separated by public rights-of-way)*. Public notices will be completed by Planning staff on the day of application submission. The Public Notice period shall be the 15 calendar days from mailing date. The mailing will consist of a Public Notice with attached reduced size plans; one set must be submitted with the application for mailing purposes of the public notification.

** Please note that if your project is determined (by the Planning Director) to have little or no negative visual effect, the public notice requirement may be waived, according to HMC Section 2.12.070(A) (2).*

Building Permit Required:

All other fences, walls, gates and columns require only a Building Permit prior to installation, unless they are part of a larger project. For Building Permits, submit three sets of construction drawings (including a site plan and footing details) to the Building Division. Fees are based on valuation.

Guidelines and Standards

Design Guidelines:

- Front fencing and gates are considered to be the “front door” to the community; as a result, these applications are reviewed in detail and are expected to meet high standards of design.
- Most successful are simple designs that are compatible with (but do not necessarily match) those in the neighborhood that are well-designed.

Maximum Height:

- The fence height most often approved is six feet (including the light fixtures, if they are mounted on top of posts).
- The maximum height permitted by ordinance is eight feet. For fencing, gates and/or columns along the street, this eight-foot height is measured from the surface of the street, or from the ground at the front property line, whichever is higher. In other words, if a driveway slopes up from the street, the height of the fencing may not exceed eight feet from the ground at the front property line.

Driveway Gates:

- Driveway gates must be set back at least 15 feet from the street to allow a vehicle to pull safely off the street in front of the gate. In some instances, additional space may be required.
- The minimum width of driveways (space between the posts, columns, etc.) is 14 feet.

Location:

- The Municipal Code prohibits private construction in the public right-of-way without prior approval from the City Council; therefore, all fences, walls and posts should be installed within the private property boundaries.
- For proposals where any portion of the planned outdoor fixture is or will be located within the right-of-way, the applicant must first obtain a right-of-way fixture approval from the city council, as set forth in HMC Section 12.12.030.
- All plans must accurately document the location of the property line in relation to the proposed fencing; the location of neighboring fencing is not necessarily an accurate representation of the property line.

Design of Fencing Along a Street:

- Fencing design should be compatible with well-designed fencing in the neighborhood.
- If the house is visible from the street, the scale, materials and quality of design of the fencing should also be compatible with those of the house.
- Fencing should be screened with landscaping—locate the landscaping between the street (or parking strip) and the fence.
- To reduce visual clutter, incorporate house numbers (min. 4” high) and mailbox (if it is approved by the U.S. Post Office) into the design and provide details in your plans.

- Be sure to provide a clear line-of-sight for exiting driveways; consult the Public Works Department to be sure you will be able to meet the minimum sight distance requirements.

Cyclone Fencing: If cyclone fencing is used, it should have a vinyl coating (black or green). Please specify the color on the plans.

Wrought Iron Fencing and Gates: Keep the designs simple. Gold-tipped spear features are not permitted.

Lights and Light Fixtures:

- No more than two posts along each street frontage should have light fixtures.
- Fixtures should have a maximum of 60 watts and be identified as such on the plans.
- Address numerals should not be internally illuminated.
- Face-mounted light fixtures, rather than top-mounted, are preferred.

Parking Strip:

Whenever work is done in the public right-of-way, the Code requires installation of a parking strip if none already exists. The ADRB often expects the development of a parking strip as part of the project, even if it isn't required by the Code. See attached handout for specifications.

Fences, Walls, Entry Gates, Columns and/or Light Posts

Application Requirements

Only complete applications can be accepted. Included here are the minimum requirements for most applications; however, each project is different. Rely on your professional judgment and expertise to ensure that your project is adequately and accurately described in your plans. If you have questions, call the Planning Division, 375-7422. Use whatever scale you believe is necessary for legibility.

A complete application will contain the following items:

1. **Application**: The attached application form completely filled out and signed (original signature, not a fax) by the current property owner.
2. **Plans**: One plan set of full-size plans (standard sheet size is 24" x 36"; larger plans will not be accepted). Plans must be collated, stapled, folded, and addressed on the outside as indicated in the attached handout. Each plan page shall contain the property address, date of the plans, and the name, address and phone number of the person who prepared the plans. Plan set should include:
 - A. **Location Map**: On the first page of your plans, show the project site in relation to neighboring properties. Show addresses of properties, names of streets, landmarks, etc. See example on page 6.
 - B. **Site Plan**: Drawn to scale (with scale noted) and fully dimensioned (include dimensions of driveway width, location of key features from property line or other landmark, such as the edge of pavement, back of curb, etc.).
 - Property lines and easements (if any) must be clearly and accurately indicated.
 - Show relative location of the street, adjoining lots, key features (existing posts, trees, mailbox, etc.).
 - Show the proposed locations (with dimensions) and sizes of fencing, posts, etc.
 - Include specifics (materials, finishes, colors, etc.) on all proposed hardscape.
 - Include details such as the swings on gates, location of keypads, etc.
 - For proposals along streets, clearly show the property lines, curb, gutter, and parking strip. Dimension these elements and indicate whether they are existing or new.
 - For proposals including work within the public right-of-way, documentation showing that a revocable encroachment permit has been issued by the Town shall be submitted.
 - C. **Elevations**:
 - For fencing along street frontages, dimensioned elevations of the full length of the proposed fencing are required.
 - For fences along a common property line, only a representative section is required.
 - Show a typical section at a larger scale for detail, if necessary.
 - Show the relationship between the fencing and the actual site grade.
 - Height dimensions from the ground and from the street grade must be provided for all columns, gates, and fencing along a street.

- Specify finishes and colors.

D. **Details:**

- Provide sufficient detail, such as the sizes and shapes of the horizontal and vertical members and other design features.
- Wrought Iron: indicate sizes, shapes, spacing and color (flat back, glossy black, verde gris, etc.).
- Columns: provide information regarding the cap detail, etc. If the column contains a mailbox, include it and the house numerals (min. 4" in height) in elevation.
- Show architectural light fixtures (low-level landscape lighting need not be shown): draw the fixture to scale and attach a manufacturer's cut sheet to each plan set; the cut sheet must specify the dimensions, finish and maximum wattage (no more than 60 watts) of the fixture.

E. **Landscaping:**

- Show existing landscaping (to remain and to be removed), with sizes (show actual, rather than stylized, canopies for trees) and species indicated.
- For new plant material, include species (botanical and common names), sizes rates of growth (fast, medium, slow), spacing, and total numbers for each plant material.
- Trees – For all trees (12" in diameter or greater) to be removed and for all existing pine trees within the public right-of-way and front setback area, provide an arborist report and incorporate the recommendations into the plan. Provide a copy of the arborist report with each plan set.

3. **Photos:** To the set of plans, attach one set of photos showing the proposed location of the fencing and/or posts. Snapshots and color photocopies are acceptable; Polaroid photos are not. Attach a photo key if there will be any question as to the location from which each photo was taken.
4. **Samples:** If you are proposing to use any unique or special materials or colors, provide a materials/sample board (no larger than 8.5" x 11").
5. **Fee:** The fee for an application for only gates and/or columns (including fencing along a street) is \$350.00 The fee for an application for fencing along a street, without including gates and/or columns, is \$286.00 A supplemental fee of \$32.00 will be collected to cover staff costs, materials and postage for the Public Notification process. If more than one preliminary staff review is required, or if there is a required revision, additional fees will be charged to cover the Town's costs.
6. **Public Notification:** Public notices will be completed and mailed by Planning staff on the day of application submission. The Public Notice period shall be the 15 calendar days from mailing date. The mailing shall include the Public Notice with attached reduced size plans; one set must be submitted with the application for mailing purposes to the Planning Division.

When the plans and the application form are complete, submit the application package, along with the filing fee, to the Planning Division for review. A complete package must be submitted or your application will be deemed incomplete. A 10 day appeal period follows your Planning approval. You may submit to the Building Division after the appeal period ends.

Town of Hillsborough

**Design Review of Fences, Walls, Entry Gates, Columns and/or
Light Posts along the street**
Application Form

(Please Type or Print Legibly)

Address of Site: _____

Authorization of property owner(s): In signing this application, I/we, as property owner(s) have full legal capacity to, and hereby do, authorize the filing of this application. I/we understand that conditions of approval are binding. I/we agree to be bound by those conditions, subject only to the right to object at the hearing or during the appeal period.

Please circle: Mr. and Mrs. / Mr. / Mrs. / Ms. / Dr.

Name(s): _____

Signature(s): _____

Mailing Address: _____
(Street or P.O. Box) (City, State and Zip Code)

Email Address: _____

Phone Number(s): _____ Add 'l Number: _____

ARCHITECT/DESIGNER: _____

Mailing Address: _____
(Street or P.O. Box) (City, State and Zip Code)

Phone Number(s): _____ Add 'l Number: _____

Email Address: _____

TOWN OF HILLSBOROUGH BUSINESS LICENSE #: _____

CALIFORNIA STATE LICENSE #: _____

Attachments: Plan Folding Instructions, Sample Location Map, Requirements for Parking Strips

Plan Folding Instructions

All plans shall be folded and addressed on the outside in the following manner:

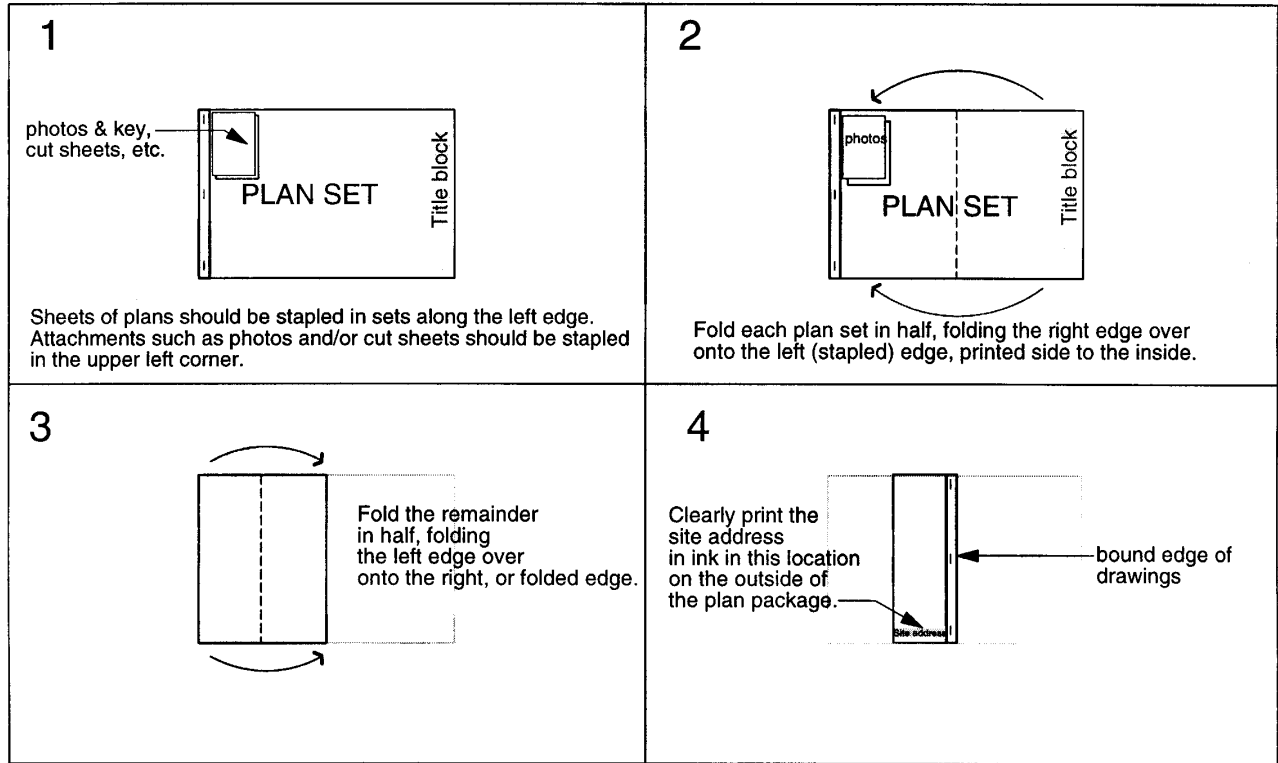

For reduced plans:

1. Staple photos, cut sheets and other attachments in the upper left corner.
2. Fold the plan sets in half, either way, depending on the orientation.
3. Clearly print the site address on the outside, as in Step #4, above.
4. Plan sets should open like a book, from right to left.

Sample Location Map

This is an example of a location map which must first page of each plan set. Show the project site nearby properties and streets. Include the addresses of all adjacent (including to the back across the street) properties. If a pre-printed map be sure that the entire street name is included for adjacent streets. The location map should be on the page in the same manner as the project

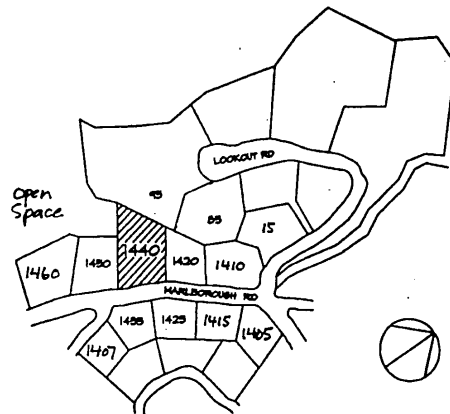

be on the relative to and is used, all oriented site plan.

THE CITY ENGINEER'S STANDARDS REQUIRE INSTALLATION OF A 5-FOOT WIDE PARKING STRIP AND CURB AND GUTTER ALONG THE STREET FRONTAGE OF THE PROPERTY FOR CONSTRUCTION PROJECTS INVOLVING MORE THAN 50% OF THE LIVING AREA OF A HOUSE OR WORK IN THE RIGHT-OF-WAY (ENCROACHMENT) THAT EXCEEDS \$30,000 UNDER THE FOLLOWING CIRCUMSTANCES:

1. PROPERTY IS WITHIN 500' OF SCHOOLS OR PUBLIC FACILITIES;
2. PROPERTY ABUTS A STREET WHICH IS LESS THAN 18' IN WIDTH;
3. NEIGHBORHOODS WITH PARKING CONGESTION AS DETERMINED BY THE POLICE CHIEF OR CITY ENGINEER;
4. PROPERTIES WITH LIMITED OR INACCESSIBLE ON-SITE PARKING AS DETERMINED BY THE PLANNING DEPARTMENT;

THE PARTIAL EXCEPTIONS TO THIS REQUIREMENT ARE:

1. IF, DUE TO EXISTING TOPOGRAPHY, CONSTRUCTION OF A RETAINING WALL GREATER THAN 18" HIGH IS REQUIRED WITHIN THE RIGHT-OF-WAY TO INSTALL THE PARKING STRIP; OR,
2. IF THE HEALTH OF SIGNIFICANT TREES WOULD BE JEOPARDIZED AS A RESULT OF THE INSTALLATION OF A PARKING STRIP (AN ARBORIST REPORT MUST BE PROVIDED WITH EACH PLAN SET AS PART OF THE PROJECT APPLICATION).

NOTE: EXCEPTIONS TO PARKING STRIP REQUIREMENTS MUST BE GRANTED IN WRITING BY THE CITY ENGINEER PRIOR TO SUBMITTING AN APPLICATION FOR REVIEW BY THE ARCHITECTURE AND DESIGN REVIEW BOARD AND INSTALLATION/REHABILITATION OF CURB AND GUTTER MAY BE REQUIRED EVEN IF THE PARKING STRIP REQUIREMENT IS NOT REQUIRED.

THE DEVELOPMENT OF A PARKING STRIP AND CURB AND GUTTER MEETING TOWN STANDARDS (SEE BELOW), INCLUDING DIMENSIONS AND SPECIFICATIONS FOR MATERIALS, SHOULD BE INCLUDED IN THE PROJECT SITE PLAN AS PART OF ALL PROJECT APPLICATIONS.

PARKING STRIP STANDARDS: ALL WORK WITHIN THE PUBLIC RIGHT-OF-WAY REQUIRES AN ENCROACHMENT PERMIT, WHICH MUST BE INSPECTED BY THE PUBLIC WORKS DEPARTMENT (PLEASE CALL 375-7444 TO SCHEDULE INSPECTIONS). THE ACCEPTABLE MATERIALS FOR THE SURFACE OF PARKING STRIPS ARE AS FOLLOWS:

- BRICKS OR INTERLOCKING PAVERS (SAND BEDDING, CROSS-SECTION DETAIL-SEE DETAIL C1b)
- DECOMPOSED GRANITE (4" WITH POLYMER ADDITIVE AND LESS THAN 5% STREET GRADE, WITH SAME 6" BASE SECTION AS CROSS-SECTION DETAIL)
- GRASS-CRETE OR TURF BLOCK (CROSS SECTION DETAIL-SEE DETAIL C1b)

PARKING STRIPS MADE OF ASPHALT, MULCH, LOOSE ROCK, AND CONCRETE ARE NOT ALLOWED.

THE 5-FOOT WIDE PARKING STRIP SHALL HAVE A 2"X6" HEADER MADE OF REDWOOD OR RECYCLED PLASTIC (TREATED WOOD IS PROHIBITED) ALONG THE BACK EDGE AND SHALL BE CONSTRUCTED WITH A TWO PERCENT (2%) CROSS-SLOPE TOWARDS THE CURB AND GUTTER.

PARKING STRIPS

(THE AREA IMMEDIATELY BEHIND THE CURB)



TOWN OF HILLSBOROUGH, CALIFORNIA STANDARD DETAIL

APPROVED BY:



 PUBLIC WORKS DIRECTOR
 DATE: JULY 8, 2013

PARKING STRIPS REQUIREMENTS

STD. DETAIL No.

C1a

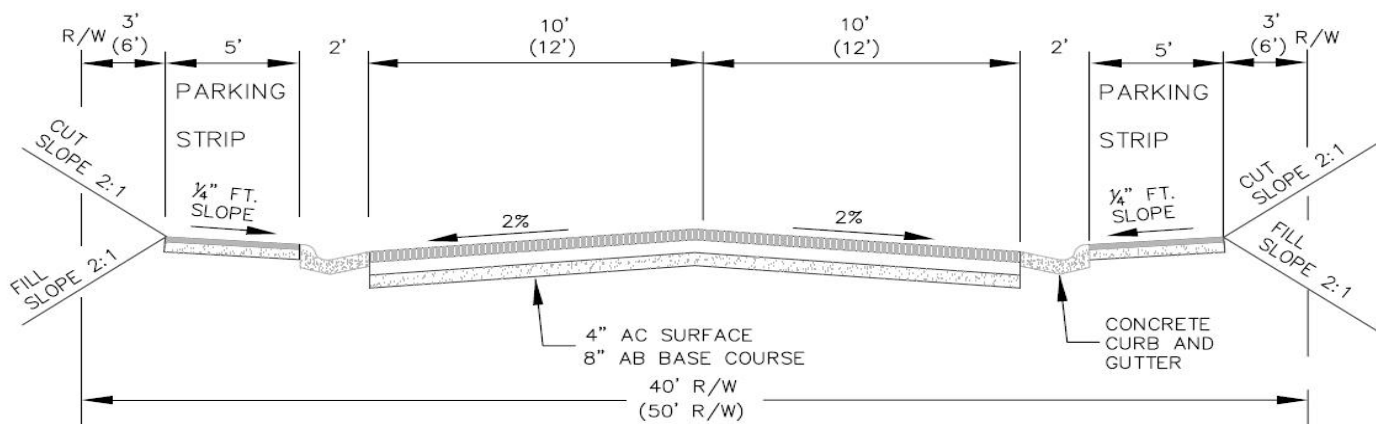
Roadway Cross Section



Not to Scale

Cross - Section Detail for Brick and Interlocking Pavers

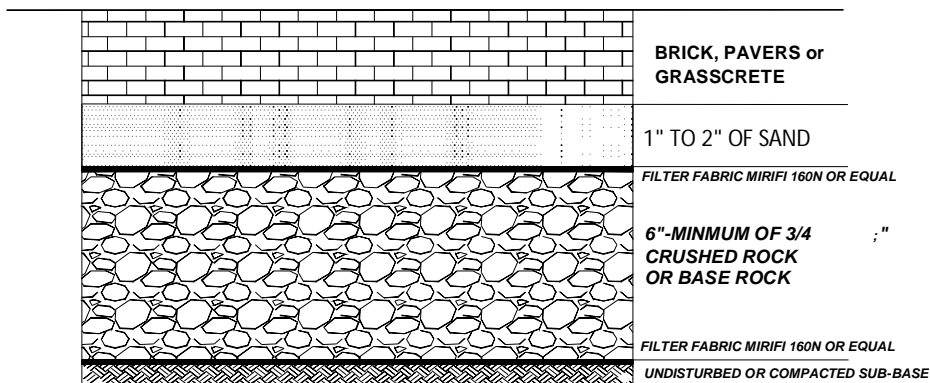

Not to Scale

NOTES:

1. HILLSBOROUGH MUNICIPAL CODE CHAPTER 12.04.120 SPECIFIES THAT THE PROPERTY OWNER IS RESPONSIBLE FOR THE MAINTENANCE AND REPAIR OF FRONTAGE IMPROVEMENTS UP TO, AND INCLUDING, THE CURB AND GUTTER.
2. PERMITEE MUST SCHEDULE TWO INSPECTIONS WITH THE PUBLIC WORKS DEPARTMENT (1) FOLLOWING COMPLETION OF FORM WORK, COMPACTION OF THE SUB-BASE, CRUSHED ROCK OR BASE ROCK SECTION AND INSTALLATION OF BOTH LAYERS OF FILTER FABRIC (2) UPON THE COMPLETION OF THE PARKING STRIP.
3. BRICK AND INTERLOCKING PAVER SECTIONS SHALL HAVE OPTIONAL PERFORATED SUBDRAINS INSTALLED AS APPROVED BY THE CITY ENGINEER.



TOWN OF HILLSBOROUGH, CALIFORNIA STANDARD DETAIL

APPROVED BY:

 PUBLIC WORKS DIRECTOR
 DATE: JULY 8, 2013

**PARKING STRIPS
 REQUIREMENTS CONTINUED**

STD. DETAIL No.
C1b